



When visibility counts and performance matters.





Table of contents

Contour Marking Tape	<u>04</u>
> V-6700 Product Series Overview	<u>04</u>
> Regulation	<u>06</u>
<hr/>	
Beaded Reflective Material	<u>08</u>
> V-4000 Series Overview	<u>08</u>
> Regulation	<u>10</u>
<hr/>	
Prismatic Reflective Material	<u>14</u>
> V-8000 Series	<u>14</u>
> Chevron Series	<u>16</u>
> Regulation	<u>18</u>

Introduction

Many people in public services have to work at the roadside, in varying weather conditions and light levels. Avery Dennison offers a complete portfolio of materials designed to protect workers such as fire fighters, police and other emergency response personnel. V-4000 and V-4000 E materials are also available to provide high visibility to non-emergency, commercial vehicles used by people such as road safety/ construction workers.

Materials in the portfolio are designed to maximise the visibility of vehicles with vivid hazard markings - giving passing drivers all of the time they need to understand what lies ahead and drive safely past - day or night.

Contour Marking Tape

Enhance night-time safety with the superior reflectivity performance of V-6700 Conspicuity Tape. This product increases the visibility of trucks and trailers during night-time driving.

It can help to reduce accidents, prevent injuries and decrease related costs such as repairs and insurance expenses. A further benefit comes from printability - for new round-the-clock advertising opportunities. V-6700 Conspicuity Tape is durable, easy to apply, provides superior night-time reflectivity and is available in 3 colours - white, yellow and red.

Colours



V-6700-B White



V-6722-B Red



V-6701-B Yellow

Colours



V-6790 White



V-6792 Red



V-6791 Yellow

V-6700 B

ECE-104 Class C compliant

- > 8 years durability
- > Increases visibility and safety of vehicles
- > Fast and easy application
- > Omnidirectional - apply in any orientation for consistent performance (unique to Avery Dennison)
- > Solid metallic layer: resists water, dirt and reflectivity loss from dents

V-6790

ECE-104 Class C compliant

- > 8 years durability
- > Increases visibility and safety of vehicles
- > Fast and easy application
- > Omnidirectional - apply in any orientation for consistent performance (unique to Avery Dennison)
- > Solid metallic layer: resists water, dirt and reflectivity loss from dents

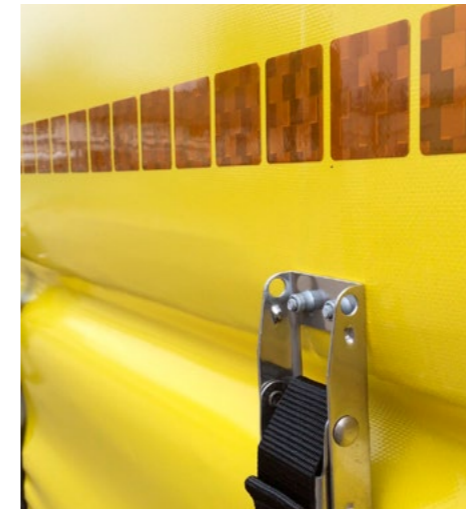

V-6790 Conspicuity Tape for Flexible Surfaces

Conspicuity Tape for Flexible Surfaces adheres securely to curtains, allowing it to withstand typical challenges during rolling and unrolling. Save time and money, reducing the need for re-application.

E-Mark

Avery Dennison V6790 Conspicuity Tape contains the E-Mark:

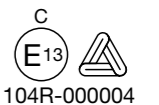

V-6700 Conspicuity Tape for Rigid Surfaces

V-6700B Series Conspicuity Tape is designed for easy night-time vehicle recognition and increased road safety. We've paid attention to every detail to ensure a superior product that's easy to apply and made to last.

E-Mark

Avery Dennison V6700B Conspicuity Tape contains the E-Mark:

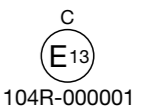

Customized Logo Conspicuity Tape for more brand awareness

V-6790 for flexible substrates and V-6700B for rigid surfaces can both be produced with a customized logo for increased brand awareness.

Please contact your local sales representative for more information.

Conspicuity Tape Application area

This page summarises where and how V-6700 and V-6700 B can be applied - note that different colours must be applied to the rear and the sides.

White and yellow can be used on the side of trucks and trailers. Red and yellow are used on the rear of a truck. **IMPORTANT: Red cannot be used on the side and white cannot be used on the rear.** Further information can be found on pages 10, 11, 12 and 13 where the ECE 104 and Regulation 48 is explained.

Side marking

a minimum of 80% of the length of the vehicle (excluding the cabin) must be marked. In special cases, this can go down to 60% for difficult applications, or 40% for especially difficult applications.

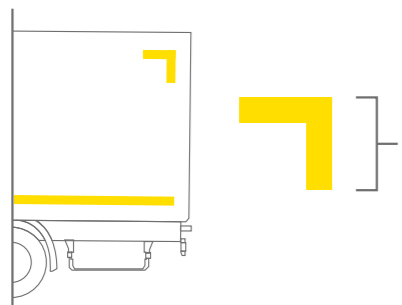
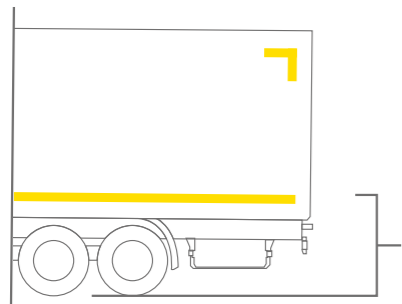
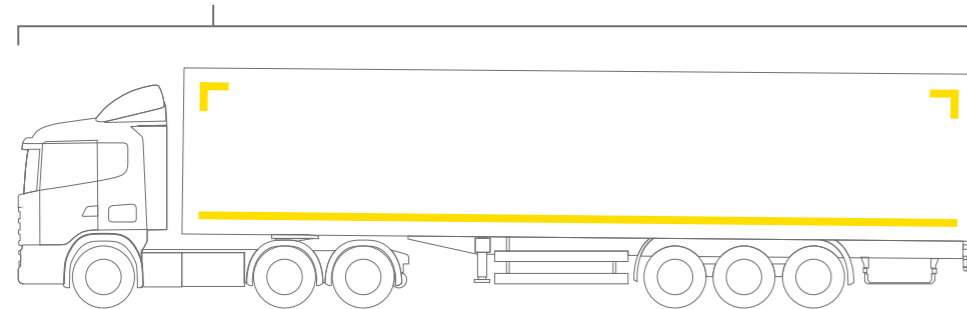

The lower line of the marking tape must be placed at least 250mm from the ground, at a maximum height of 1500mm. In special cases, this can be extended to 2500 mm.

The length of the upper corner markings must be at least 250mm. Upper corner markings should be applied as high as is practical, but within 400mm of the upper extremity of the vehicle.

In cases where a top corner marking is not possible, due to the construction of the vehicle, a line marking on its own is allowed.

Rear marking

Full contour marking is required to the rear, unless this is impossible due to the vehicle's construction. Maximum height requirements for the lower line are the same as indicated for the markings to the side (see above).

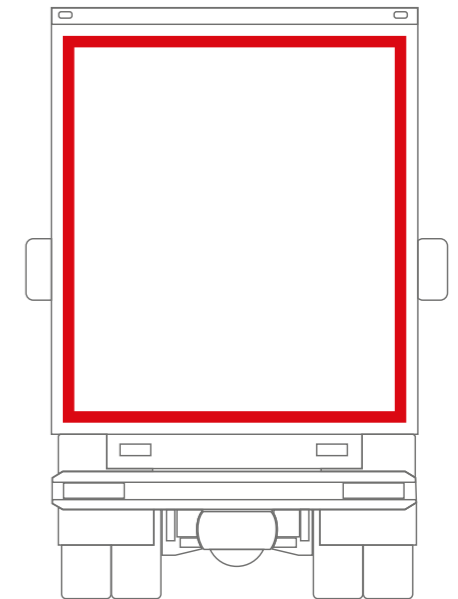

Rear and side markings

Full contour marking is required to the rear, unless this is impossible due to the vehicle's construction. Maximum height requirements for the lower line are the same as indicated for the markings to the side (see above).

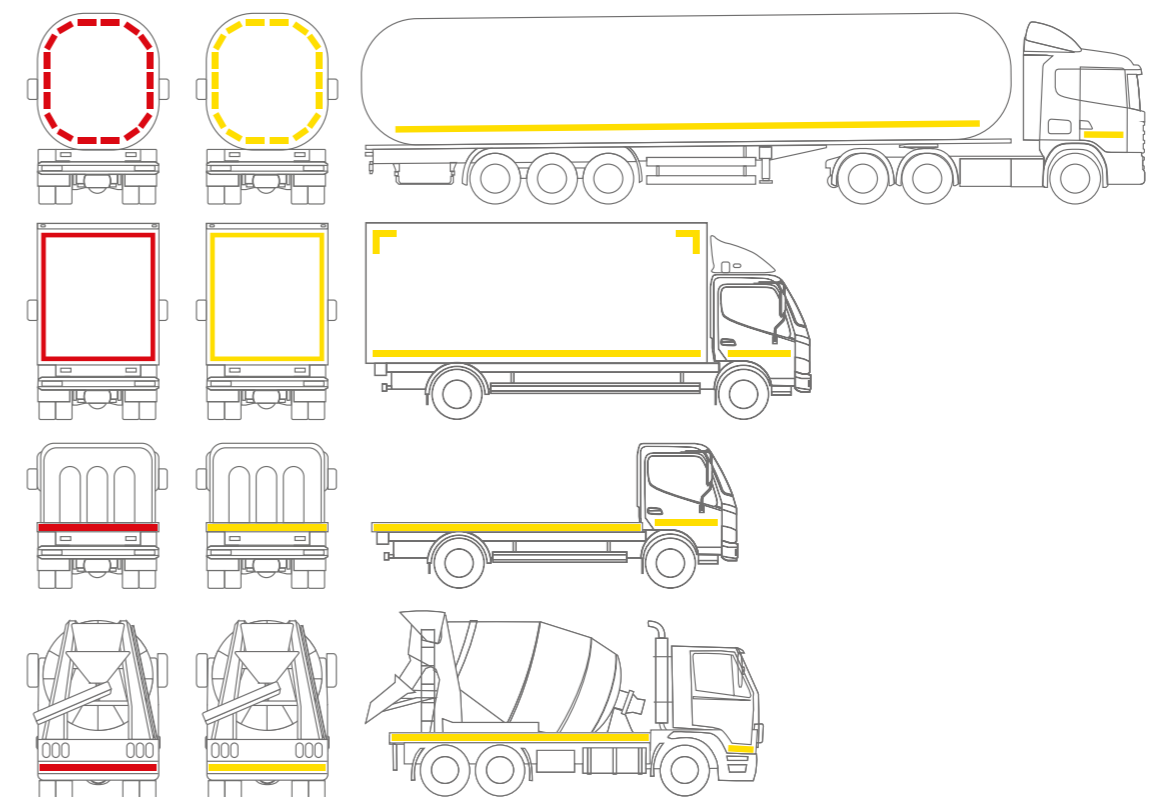

Avery Dennison® V-4000

Avery Dennison® V-4000 is a high-quality, beaded, retro-reflective cast film, tailored for long-term commercial and emergency fleet applications. The material is suitable for cutting and weeding, and printing on screen presses. The white version is digitally printable. A high level of reflectivity makes this a very versatile product that offers exceptional value for vehicle, architectural, and general signage applications - wherever conformability and extended durability are important.



V-4000
Orange



V-4000
Blue



V-4000
Black



V-4000
Red



V-4000
Yellow



V-4000
White

Fleet manager

- > Striking brand visibility 24 hours: increase vehicle appearance and safety
- > Up to 7 years warranted durability
- > Several design options: can be printed and cut
- > 6 high gloss colours (or match your corporate colour)
- > Removes easily and cleanly (e.g. end of lease)

Converter friendly

- > Quick and easy application (with Easy Apply™) + slideability and repositionability
- > Superior printability across all platforms
- > Sign-cutting possible
- > Superb conformability to moderate curves



Digital printed V-4000 used to increase brand awareness.

Avery Dennison® V-4000 E

Avery Dennison® V-4000 E Retro-Reflective film is an excellent choice when day and night-time visibility is required. This high-quality, beaded, retro-reflective cast film is designed for truck and trailer applications in Europe. V-4000 E comes with a watermark certifying ECE104 - Class E approval. Suitable for long-term commercial and emergency fleet applications.

Fleet manager

- > Striking brand visibility 24 hours: increase vehicle appearance and safety
- > Up to 7 years warranted durability
- > Several design options: can be printed and cut
- > 6 high gloss colours (or match your corporate colour)
- > Removes easily and cleanly (e.g. end of lease)

Converter friendly

- > Quick and easy application (with Easy Apply™) + slideability and repositionability
- > Superior printability across all platforms
- > Sign-cutting possible
- > Superb conformability to moderate curves



V-4000 E applied on truck trailer according to ECE regulation.

V-4000E
Orange



V-4000E
Blue



V-4000E
Black



V-4000E
Red



V-4000E
Yellow



V-4000E
White



Regulation ECE104



ECE 104 is the regulation outlining technical requirements for approved retro-reflective marking tapes for trucks and trailers in Europe.

The materials are divided into 3 classes:

Class "C"	Material for contour marking
Class "D"	Material for distinctive markings/graphics intended for a limited area
Class "E"	Material for distinctive markings/graphics for an extended area

In terms of reflectivity, Class "C" is the highest grade, and Class "E" the lowest.

ECE 104 does not include any details on the actual application of tapes onto vehicles - this information is found in Regulation 48.

Note: When ECE 104 was incorporated into Regulation 48, Annex 9 (which previously contained application guidelines) was deleted from the regulation.

Where to apply V-4000 E

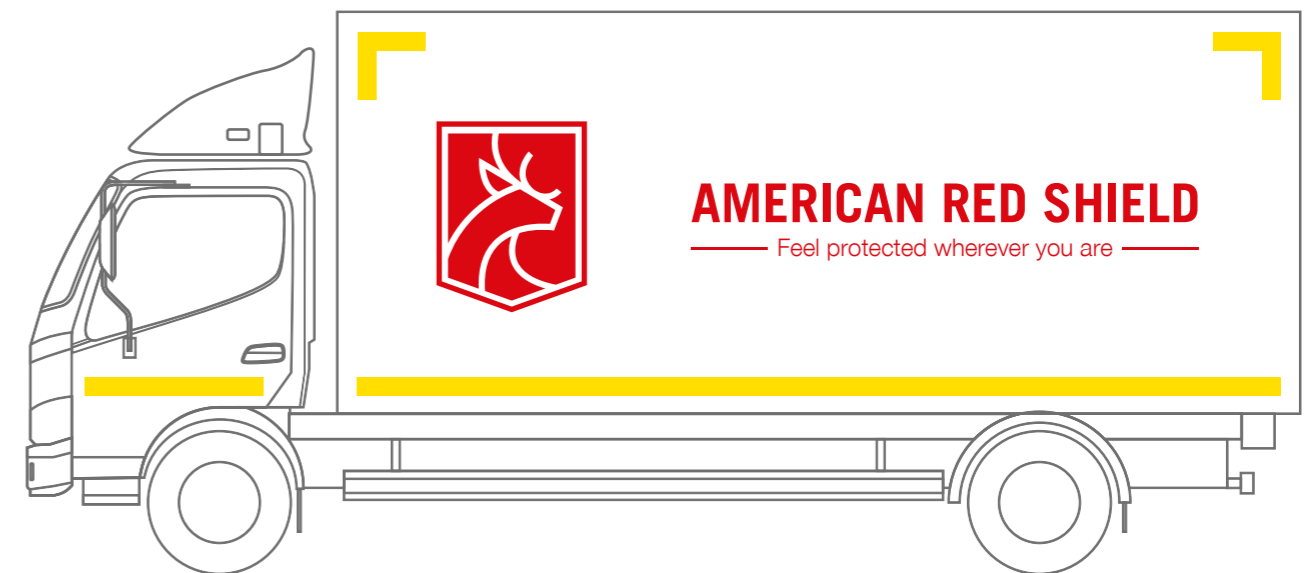

Logo and Lettering created with V-4000 E, in compliance with the ECE regulation.

Regulation 48













Regulation 48 includes the mandate for Regulation ECE 104 markings, and specifies the conditions for this - i.e. which vehicle types must comply, which colours should be used, etc. This regulation encompasses all technical aspects relating to the application of tapes that must be approved according to the technical requirements in ECE 104.

Regulation 48 includes only Class “C” conspicuity markings.

Because Regulation 48 deals with lighting and light-signalling devices, neither class D nor class E in ECE 104 are included in or referred to by this regulation. The use of these materials is left to national authorities. Previously, when ECE 104 included application guidelines, it was a requirement that graphics made with Class D or E materials had to be placed within a full contour marking. Today, this is not a requirement in Regulation 48, but something which is decided at a national level.

Your own national lighting regulations may differ from the general guidance given here, it is important to check before installation.

For all new registrations		Pursuant to R/2007/35/EG	Binding from 10 July 2011	Permitted	Not permitted
M	Motor vehicles for passenger transportation with a minimum of 4 wheels, and motor vehicles for passenger transportation with 3 wheels and a maximum weight over 1t.				
M1	Motor vehicles for passenger transportation with a maximum of 8 seats, apart from the driver's seat.				✗
M2	Motor vehicles for passenger transportation with more than 8 seats, apart from the driver's seat, and a maximum weight of up to 5t.			✓	
M3	Motor vehicles for passenger transportation with more than 8 seats, apart from the driver's seat, and a maximum weight over 5t.			✓	
N	Motor vehicles for goods transportation with a minimum of 4 wheels, and motor vehi-				
N1	Motor vehicles for goods transportation with a maximum weight of up to 3.5t.			✓	
N2	Motor vehicles for goods transportation with a maximum weight of 3.5t to 7.5t.*			✓	
N2	Motor vehicles for goods transportation with a maximum weight of 7.5t to 12t.*		✓	✓	
N3	Motor vehicles for goods transportation with a maximum weight over 12t.*		✓	✓	
O	Trailers (including semi-trailers)				
O1	Trailers with a maximum weight of up to 0.75t.				✗
O2	Trailers with a maximum weight of 0.75t to 3.5t.*			✓	
O3	Trailers with a maximum weight of 3.5t to 10t.		✓	✓	
O4	Trailers with a total weight over 10t.		✓	✓	

International classification according to Regulation 70/156/EEC dated 6 February 1970. The class affiliation of your motor vehicle can be found on the first page in fields “J” and “5” on new vehicle registration documents. * Not prescribed, but permitted, on a chassis with a driver's cab, incomplete vehicles and semi-trailer tractor units.

Avery Dennison® V-8000

Avery Dennison® V-8000 Series High Visibility Reflective Film is engineered to improve the day and night-time visibility of emergency response, utility, and construction fleets. These materials offer durable, vibrant daytime colours. At night, the bold, high-quality microprismatic retroreflective elements return light efficiently at a wide range of angles. The single, solid metallic layer construction simplifies application, and eliminates the requirement for edge sealing.



V-8000
White



V-8005
Blue

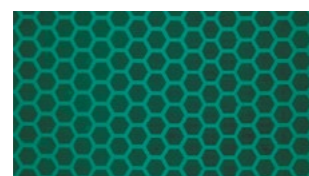

V-8007
Green



V-8008
Orange



V-8013
Fluorescent
Yellow-Green



V-8014
Fluorescent
Orange

Highest possible emergency vehicle reflectivity - the all-in-one prismatic solution for design flexibility and long-term durability.

Fleet manager

- > Omnidirectional for homogeneous night-time visibility (unique to Avery Dennison)
- > Solid metallic layer: resists water, dirt and reflectivity loss from dents
- > Striking day/night-time appearance
- > Can be printed and cut
- > Long-term durability:
 - 7 years (standard colour)
 - 5 years (fluorescent)

Converter friendly

- > Omnidirectional: apply in any orientation and obtain consistent performance (unique to Avery Dennison)
- > Solid metallic layer: eliminates edge sealing - save time and money when converting/applying
- > Easy to apply and conforms to simple curves
- > Convert with digital print, screen print and sign cut
- > 1.22 meter width for design flexibility and less scrap
- > RA2-C material to according to ASTM D4965, HOSDB, TSPESC-B and DIN 30710.



Chevron

Conditions on the roads can sometimes endanger the lives of people working in public services. Those needing protection at all times of day include fire fighters, police, emergency response personnel, and road safety/construction workers.

Effective hazard markings make vehicles much more visible, and the high performance of micro-prismatic reflective materials ensures that emergency vehicles stand out to passing

motorists day and night. A vivid fluorescent yellow/red improves the day-time visibility of emergency vehicles in unfavourable weather conditions, giving drivers time to respond to hazards ahead.

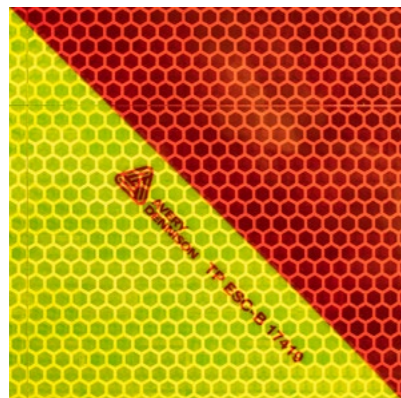
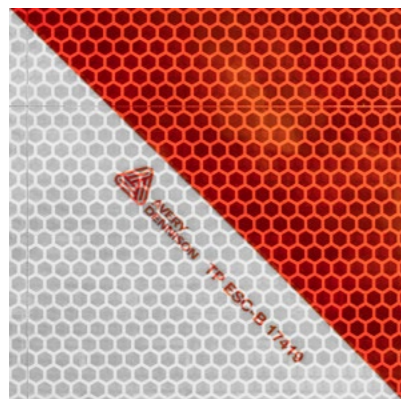

Fleet manager

- > Improved safety, with better visibility of moving or stationary vehicles
- > Striking and bold day-time appearance
- > Bright and vivid night-time presence
- > Solid metallic layer - resists water, dirt and reflectivity loss from dents
- > Long term durability
- > Higher resistance against abrasion

Converter friendly

- > Easy to apply and conforms to simple curves
- > Compliant with TPESC-B (France) and DIN 30710 (Germany)
- > Available in several sizes:
 - 0.141 x 45.72m
 - 0.282 x 45.72m
 - 1.2 x 22.86m

Recommended uses

- > Marking for emergency vehicles, roadside services and technical support fleets

Code	Product description	Direction	SIZE (WIDTH X LENGTH)
White/ Red (According to TPESC-B and DIN 30710)			
BQ2240001	Chevron White/Red	Left Marking	0.141 x 45.72m
BQ2290001	Chevron White/Red	Right Marking	0.141 x 45.72m
BQ2240002	Chevron White/Red	Left Marking	0.282 x 45.72m
BQ2290002	Chevron White/Red	Right Marking	0.282 x 45.72m
BQ2240003	Chevron White/Red	Left Marking	1.2 x 22.86m
BQ2290003	Chevron White/Red	Right Marking	1.2 x 22.86m
Fluorescent Yellow/ Red (According to TPESC-B)*			
BQ2230001	Chevron Yellow/Red	Left Marking	0.141 x 45.72m
BQ2220001	Chevron Yellow/Red	Right Marking	0.141 x 45.72m
BQ2230002	Chevron Yellow/Red	Left Marking	0.282 x 45.72m
BQ2220002	Chevron Yellow/Red	Right Marking	0.282 x 45.72m
BQ2230003	Chevron Yellow/Red	Left Marking	1.2 x 22.86m
BQ2220003	Chevron Yellow/Red	Right Marking	1.2 x 22.86m

*Note that special permission is required to use fluorescent yellow/red hazard stripes and fluorescent contour strips on service vehicles.

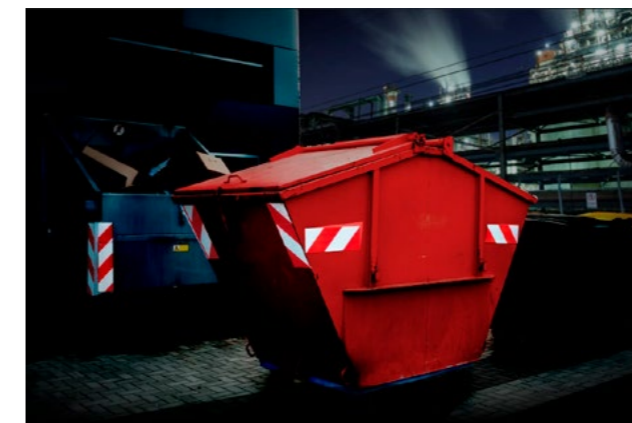

Avery Dennison Chevron White/Red used for container hazard marking.



Avery Dennison Chevron White/Red used for vehicle marking according to DIN30710 and TPESC-B.

Chevron DIN 30710

In order to obtain special permission under article 35, para. 6 of the German Road Traffic Regulations (StVO), hazard markings in accordance with DIN 30710 must be attached to the vehicle. Accessory equipment or vehicle superstructures must also be provided with this type of reflective foil. The standard not only describes red-and-white strips, it also contains stipulations for affixing them to, and arranging them on, the vehicle. In practice, although many vehicles are fitted with such hazard markings, in many cases they are not arranged in compliance with standards – and this includes government vehicles.

These pages explain the relevant criteria, particularly with regard to affixing markings in a professional manner.

Motor vehicle hazard markings must

- > be attached symmetrically at a maximum possible distance from the vehicle's external contours
- > not be hidden by accessory equipment, trailers, etc.
- > also be affixed to the sides of vehicles moving transversely to the direction of travel
- > be affixed at the height of headlamps or tail lights, where possible.

	Version I (starting with red)	Version II (starting with white)	Amount at the front (front view)	Amount at the back (front view)	Typical errors
Standard area 141 x 141 mm			8 pieces 4x pointing left 4x pointing right	8 pieces 4x pointing left 4x pointing right	Standard areas are individually inadmissible
Individual area 141 x 282 mm			4 pieces 4x pointing left 4x pointing right	4 pieces 4x pointing left 4x pointing right	
Minimum area 141 x 564 mm			2 pieces 1x pointing left 1x pointing right	2 pieces 1x pointing left 1x pointing right	
Minimum area 282 x 282 mm			2 pieces 1x pointing left 1x pointing right	2 pieces 1x pointing left 1x pointing right	

How to apply

Horizontal



Vertical



Horizontal and vertical combined



Chevron DIN 30710

How and where to apply

The specifications set out in DIN 30710 are definitive - stating that hazard markings on the front and rear must comprise 8 standard areas each (8 standard areas on the front and 8 on the rear) - meaning a total of 16.

8 standard areas are required for each surface to be identified (4 pointing left and 4 pointing right). Hazard markings may not be adhered to individual standard areas. Standard areas must, as a minimum, be combined with individual areas. Individual areas may, as the name suggests, be labelled separately from each other, but should always begin on the outer edge of the vehicle.

The minimum area comprises two individual areas and contains 4 standard areas. They may be rectangular (141x564mm) or square (282x282mm), or form a combined area. If individual areas are combined, always ensure the hatch lines are in the right direction. Areas adapted to the contours of the vehicle must include a minimum of two standard areas (in which case two additional standard areas are required per direction).

Application Examples

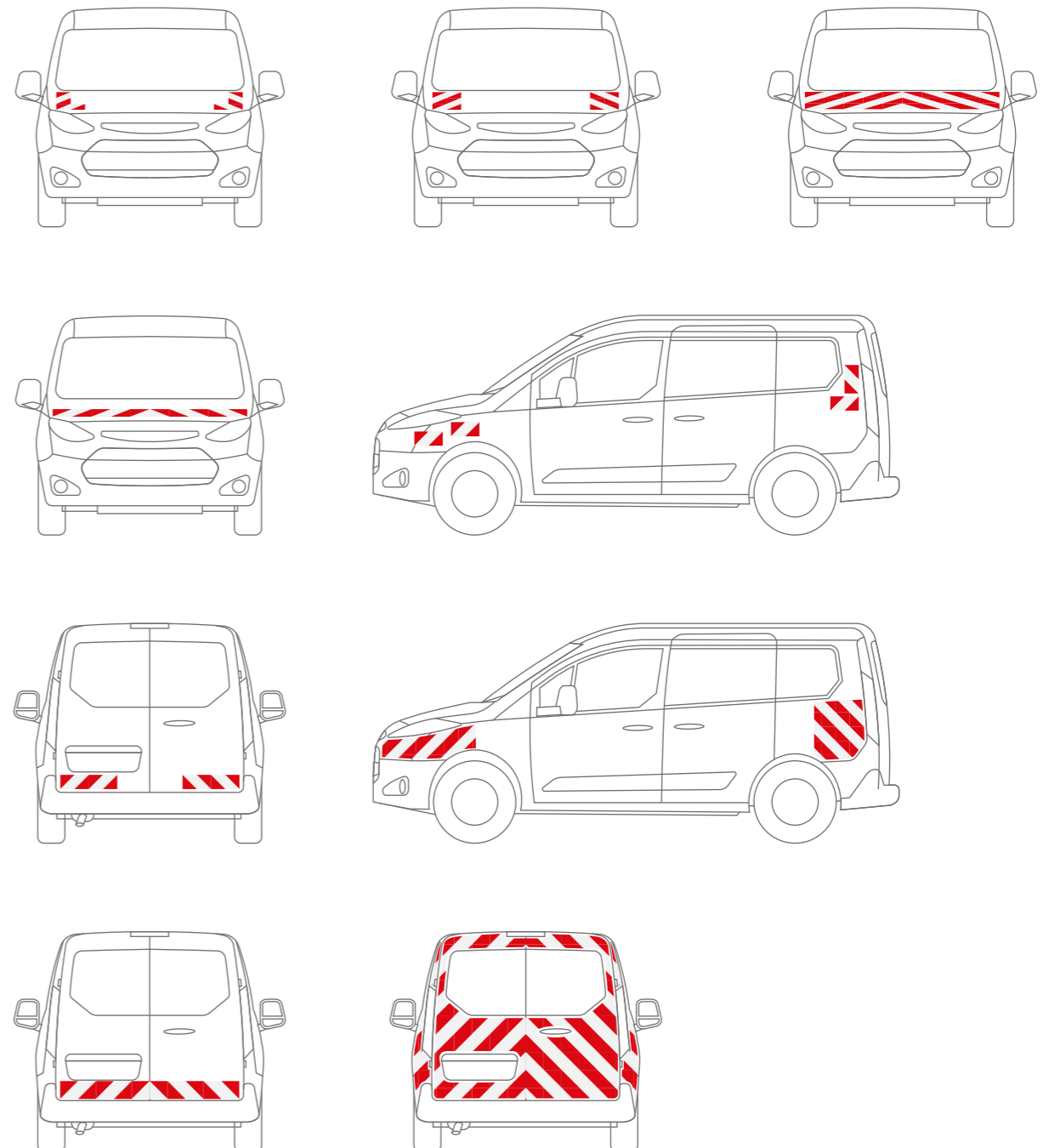

Regulation DIN 14502-3

According to a recommendation in DIN 14502-3, large areas of red/neon yellow shading can be applied to the rear of fire engines. The prototype for this type of hazard shading originates in France, where it complies with the norm for French fire engines, and is approved to TPESC, class B. No general approvals exist for German fire engines as of 2015. However, in principle, it can be used within the context of a certificate of exemption that can be applied for by reference to DIN 14502-3 (design of emergency vehicles).

This draft standard sets out the requirements for the external colour scheme, internal colour scheme and other colouring for fire engines, whereby the external colouring is painted on or applied by means of adhesive foil. It applies to fire engines in accordance with DIN EN 1846-2 and in deviation from DIN EN 1846-2:2002-03, 1.2, and also to all crew transportation vehicles and fire engines with a total mass of up to 21t.



Regulation TPESC-B

The Order dated 7 April 2006, amending the Order dated 20 January 1987, concerns additional markings for emergency response vehicles and slow-moving vehicles. It determines with precision the configuration, positioning and identification of the additional markings and optical performance of the retro-reflecting system (Class A and Class B).

All response, works and service vehicles using the public highway must carry appropriate markings that comply with the regulations, and must be marked with red and white horizontal marking strips on each side and on the front and rear of the vehicle.

Public interest priority fire fighting vehicles are equipped with additional marking devices, comprising strips made up of Class B red retro-reflecting surfaces and alternating yellow fluorescent retro-reflecting surfaces.

At the front and rear, the marking strips shall be distributed symmetrically relative to the median

vertical longitudinal plane of the vehicle, and shall be as continuous as possible.

The TPESC approval number must appear on every white or yellow stripe on the marking strip.

Class A retro-reflecting strips are visible at 80 metres (regulatory minimum). They are used in the urban environment and on the road network where traffic speed is below 90 km/h.

Class B (or Class 2) retro-reflecting strips are visible at 250 metres. They are used on the road network where traffic speed is greater than or equal to 90 km/h.





graphics.averydennison.eu

DISCLAIMER - All Avery Dennison statements, technical information and recommendations are based on tests believed to be reliable but do not constitute a guarantee or warranty. All Avery Dennison products are sold with the understanding that purchaser has independently determined the suitability of such products for its purposes. All Avery Dennison's products are sold subject to Avery Dennison's general terms and conditions of sale, see <http://terms.europe.averydennison.com>



©2018 Avery Dennison Corporation. All rights reserved. Avery Dennison and all other Avery Dennison brands, this publication, its content, product names and codes are owned by Avery Dennison Corporation. All other brands and product names are trademarks of their respective owners. This publication must not be used, copied or reproduced in whole or in part for any purposes other than marketing by Avery Dennison.